



## A Second Layer Grid Protection System Based on Solid State Relay in Automatic Bi-Directional Smart Meter

---

Suvamoy Bhattacharyya, Ushnik Chakrabarti, Anindya Nag and Sudhangshu Sarkar

EasyChair preprints are intended for rapid dissemination of research results and are integrated with the rest of EasyChair.

November 7, 2019

# A Second Layer Grid Protection System Based on Solid State Relay in Automatic Bi-Directional Smart Meter

Suvamoy Bhattacharyya  
Electrical Engineering  
Narula Institute of Technology  
Agarpara, India  
[suvamoy.bhattacharyya@gmail.com](mailto:suvamoy.bhattacharyya@gmail.com)

Ushnik Chakrabarti  
Electrical Engineering  
Narula Institute of Technology  
Agarpara, India  
[ushnikchakrabarti@gmail.com](mailto:ushnikchakrabarti@gmail.com)

Anindya Nag  
Dept. of Engineering  
DCI – CNAM Institute, DGUT,  
Dongguan, China

Sudhangshu Sarkar  
Electrical Engineering  
Narula Institute of Technology  
Agarpara, India  
[sarkar.sudhangshu@gmail.com](mailto:sarkar.sudhangshu@gmail.com)

**Abstract** – Now a days the industrial and non-industrial consumers are using traditional electromechanical as well as digital energy metering instruments. The prime reason to upgrade the traditional electromechanical energy meter is to avoid the cost of labour and executives, lack of flexibility, reliability, accuracy and live tracking system. Automatic Metering Interface (AMI) can be used to improve the accuracy in billing, live monitoring of energy consumption and economic power supply. Such transparency has been achieved by using smart digital energy meter with the help of Zigbee, Worldwide Interoperability for Microwave Access X (WIMAX), Global System for Mobile (GSM) communication based wireless data transfer mode and PLC communication based wired data transfer mode. AMI can be provided to measure the consumed conventional energy by the consumer as well as power delivered to the grid from the localized small scale non-conventional power generation unit. This can be helpful to calculate the net amount of power transfer between suppliers and consumers with dynamic pricing through bidirectional communication system containing securely paired master slave mode during installation. The AMI can also secure the power transmission and localized power generation unit from the indiscriminate electrical faults. AMI offers reliable protection and securely maintain the stability of power system with the preliminary fault detection through an inbuilt tripping circuit designed and installed against the standard value of the parameters associated with the power system. This paper presents a brief review of research work going on construction of the smart meter, comparison of the internal construction of the AMI, advantages and disadvantages of AMI in present system and communication system of the smart metering technology along with the new approach of the tripping mechanism to handle the preliminary faults in the power system intelligently.

**Keywords** – AMI, AMR, Bidirectional Smart Meter, Flexi Meter, Tripping Mechanism in Smart Meter.

## I. INTRODUCTION

In the twentieth century electricity is there in most of the rural areas. Energy meter is one of most important components in the power system. In the nineteenth century electricity meter was invented with the principle of electromagnetism.

Electromechanical energy meter measures the amount of power consumed by the load attached at the consumer end with the help of current coil and pressure coil by means of electromagnetism and mechanically arranged gear set to show the value of consumed power by the consumer. Later in the twentieth century, microprocessor based measurement of consumed energy has been done to increase the accuracy, reduction of self-power consumption along with the minimization of labour cost in the form of electronic energy meter. After the regular research and development, this electronic meter has been converted to smart energy meter by attaching the wireless communication system to transfer the data from the consumer end to power provider end. Now a days, bi-directional smart meter able to measure the incoming power to the consumer end as well as the outgoing power towards the grid from the localized power generating station at a time, it also able to calculate the net power consumed by the consumer or delivered to the grid along with the power factor measurement. In India, electromechanical energy meter are mostly used than the smart meters whereas outside the India, especially in advanced countries smart meters are effectively used to manage the metering system accurately with greater reliability and minimum human involvement. It is the best way of approach to incorporate the flexi metering system and fault protection system along with the automatic smart bi-directional meter (ASBEM).

### A. Introduction of Energy Meter

In the power system, broad way of classification distinguishes the energy meter in three parts: Electromechanical Energy Meter, Digital Energy Meter and Smart Energy Meter.

### B. Electromechanical Energy Meter<sup>[1], [2]</sup>

In constructional aspect, the electromechanical or electromagnetic energy meter consists with four main segments: Driving System, Moving System, Braking System and Mechanical Registering System. The electromagnetic core manufactured with laminated silicon-steel along with two driving electromagnets out of which shunt electromagnet directly gets connected to the available electrical supply and excited as per the available supply voltage, series electromagnet gets excited as per the amount of load current flows through it. The limb in the middle portion made up with

copper bands which can be aligned with the flux generated by the shunt electromagnet. The moving system made up with aluminium disc mounted on shaft made with alloy materials. The induced eddy current on the disc gets cut down by the stationary magnetic flux. When the load consumes electrical power, the interaction within the electro-magnetic flux and the disc, produces a deflecting torque on the disc and it starts rotating; according to gear train, the display unit shows the amount of consumed power by the load. The rotation of the disc counts the consumed energy in Kilowatt-hour.

### C. Benefits of Electromechanical Energy Meter [2], [3]

1. **Robustness:** These meters are strong enough with respect to digital energy meters as they have small and sensitive components.
2. **Mechanical Dial of Energy Meter:** Readings of the dial of electromechanical energy meter is quite hard to modify.
3. **No Use of Battery:** Due to the presence of mechanical dial, storing of readings are independent of external or main power supply.

### D. Drawbacks of Electromechanical Energy Meter [2], [3]

1. **Future Up-gradation:** Continuous up-gradation process is not applicable.
2. **Accuracy Limits:** Disk meters commonly gives class 2 accuracy.
3. **Limited Measurements:** As disk meters have only one dial so they can measure active or reactive power at a time. Moreover, they cannot measure MDIs, instantaneous power, voltage, current or other important parameters.
5. **Highly Exposed to Electricity Stealers:** These meters can be manipulated by adapting the disk blocking or reversing technique on it.
6. **Power Consumption:** Self running power consumption is high enough.

## II. SMART ENERGY METER [2], [3]

Smart energy meter basically consists of sensors, microcontroller and wireless module to measure the consumed energy by the consumer and the readings are send to the power supply provider end. Sensor senses the data of the exact power consumed by the load, sends the data to the microcontroller to process accordingly, takes the pre-defined actions set there inside the controller unit. Wireless communication module used to upload the data i.e, reading to the server for the better transparency, live tracking of the consumed power, real time recording and load monitoring system at the consumer end.

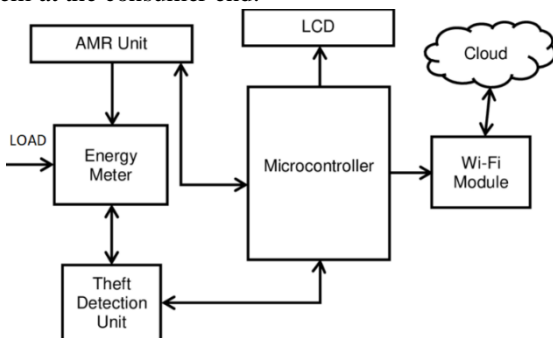

Fig. 1: Block Diagram of Smart Energy Meter  
A. *Benefits of Smart Energy Meter* [12]

The expected benefits of the installed smart metering system are listed in 3-D chart. The smart energy meter records much more detailed and accurate energy consumption information than conventional energy meter. In addition, the smart meters provide more facilities to consumers and electric power companies, such as, to reduction of the self-power consumption or losses, grid reliability, quick response to consumer power demand.

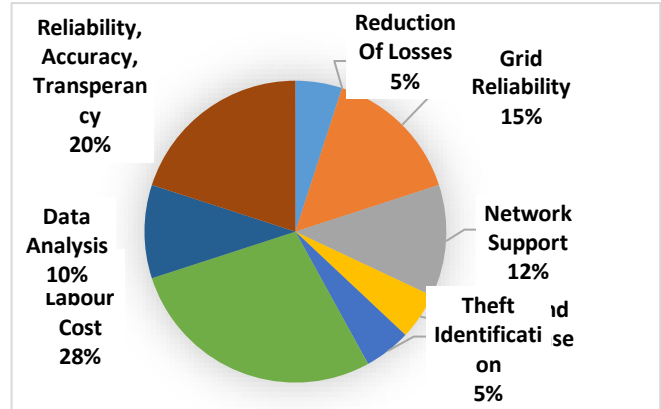

Fig. 2: Benefits of Smart Energy Meter in Graphical Form  
Advantages are:

1. Minimalistic design.
2. Non degradation of magnetic, mechanical components.
3. Higher accuracy.
4. Better reliability.
5. Real Time Pricing and Monitoring system available – IHMD (In Home Monitoring Display), usage chart in web.
6. Minimization of labour cost, optimization of human resources.
7. Long Life with minimum maintenance.
8. Remote monitoring and controlling facility available.
9. Self-power consumption is quiet less than the electromechanical energy meter.

### B. Drawbacks of Smart Energy Meter

There are some drawback comes in the aspect of socio-economical, psychologically adoption of new smart metering system as well as the expert in the several technical persons are required to maintain the smooth operation. Some of them are listed below:

1. The cost in terms of personnel training and equipment development and production to transition to a new technology and new set of processes.
2. Managing negative public reaction and acquiring customer acceptance of the new meters.
3. Making a long-term financial commitment to the new metering technology and the related software involved.
4. Managing and storing vast quantities of the metering data collected.
5. Ensuring the security and privacy of metering data.

6. Initial cost high enough to establish and install the smart meter.
7. Battery power required for self-driving and storing the data.
8. Error correction requires expert for programming.
9. Network connectivity poor, data loss may occur.

C.Plans for Installation of Smart Meters by 2020e <sup>[12]</sup>

As per the goals set by the different countries like Pakistan, Japan, United States etc. to grab the benefits of smart meter by 2020e, this bar formatted chart is prepared collecting the data from different research papers.

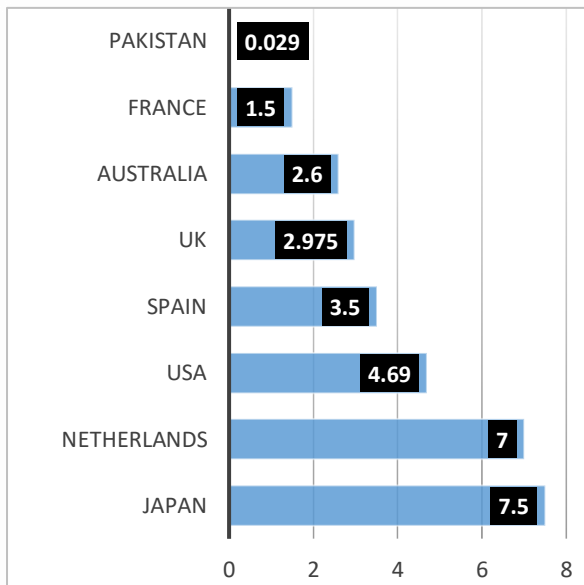

Fig. 3: Plans for 2020e – Installation of Smart Meters in Different Countries

### III. CONSTRUCTION OF AUTOMATIC SMART BIDIRECTIONAL ENERGY METER (ASBEM)

In the ASBEM, the power flows from the conventional source to the consumer end as well as the power generated from the non-conventional source goes to the grid. Constructional elements of ASBEM are different by different manufacturers available in the market as well as in research-development laboratory. Block diagram shows the basic constructional details of the ASBEM.

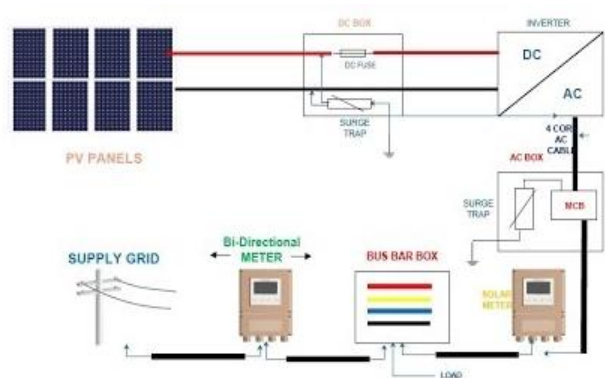

Fig.4: Block Diagram of ASBEM

Out of these 8051, PIC or AVR family, any of the microcontroller is used to manufacture the ASBEM generally which collects either the data of voltage and current from the sensors along with the corresponding power factor (PF) from the zero crossing detector (ZCD) integrated circuit (IC) or by the help of the CS XXXX (example: CS5460) or ADE XXXX (example: ADE7758) series IC which can measure the voltage and current data directly within its specified limit. Either Current Transformer (CT) or Potential Transformer (PT) or both at a time used to step down the current and voltage within the specified limit of the IC subsequently. The microcontroller calculates the energy consumed by load from these readings. Either Liquid Crystal Display (LCD) or Light Emitting Diode (LED) display or OLED is used to show the readings which is fed by the microcontroller. In AMI or ASBEM Zigbee, WIMAX, GSM based wireless data transfer mode and PLC based wired data transfer mode is used to transfer the measured reading from the meter to the server at the supplier end.

### IV. COMPARATIVE STUDY

#### A. Comparison within The Fundamental Constructional Elements with Microcontroller

The mostly used fundamental constructional elements of ASBEM along with microcontroller is energy measurement IC like CS5460, ADE7758<sup>[26]</sup>, SA9602HPA etc. to measure energy consumed by the load with the voltage and current readings with respect to real time constantly. The voltage and current sensors along with ZCD is also the another method to measure the energy consumption with respect to real time. Comparison of these individual methods are listed below at Table 1.

Description of The Constructional Elements		CS XXXX	ADE XXXX	Voltage Sensor, Current Sensor, ZCD
	Accuracy	Total Harmonic Distortion (THD): 74 Db Common Mode Rejection Ratio (CMRR) (DC, 50, 60 Hz): 80 dB typically	CMRR: 0.01% typical 0.1% accurate	0.2% accurate
	Linearity	0.1% Energy 1000:1 dynamic range typical	500:1 range IRMS 20:1 range VRMS Typical	0.2% Energy Max. Full Scale (FS) typical
	Reliability	Medium	High	Low
	Range	Low (230V AC typical)	High (440V AC typical)	Low (Step Down To 25V To 5V DC typical)
	Life	Medium	Long	Low
	Directional Measurement	Bi Directional	Bi Directional	Uni Directional
	Complexity	Medium	Medium	Less
	IC Cost In INR approximately	50	200	450
	Clock Pulse Train	Internal 4.096 MHz typical 3 MHz Min. to 20 MHz Max.	Internal 10 MHz typical 5 MHz Min. to 15 MHz Max.	Not Required
	Measurement	AC and DC	AC and DC	AC and DC
	Number Of Phase Measurement	Single	Multi	Single
	Conversion For Measurement	DC	DC	DC or AC
	Self-Power Consumption	12 W typical	70 W typical	50 W typical

### B. Comparative Study of The Communication Methods

There are several communication methods available to transmit the data measured by the microcontroller in the smart energy meter like WIMAX, PLC, WLAN, Zigbee, GSM, Radio Frequency (RF), Light Fidelity (LIFI) etc. There are several benefits as well as drawbacks of these

communication methods like speed of uploading the data, network availability, overlapping the frequency, probability of data loss, frequency range, cost and range etc. The comparison between the commonly used communications method are discussed below in table 2.

of Communication Methods		WIMAX	Power Line Carrier	WLAN	Zig-bee
	General usage	Point-to-point wireless transport for voice, data, video etc.	Also known as power line communication, Broadband over Power Lines; Systems for carrying data on a power conductor, for WAN applications;	Wireless networking for LAN and WAN; widely used for indoor wireless LAN.	Low data rate, long battery life and secure networking; In-between Wi-Fi and Bluetooth.
	frequency range	2.3GHz, 2.5GHz, 3.5GHz licensed bands; 450MHz, 700MHz are also used.	1.7MHz to 80MHz. Most providers rely on the 1-30 MHz spectrum bandwidth for BPL transmission.	Unlicensed: 2.4GHz and 5GHz; Direct Sequence Spread Spectrum (DSSS), OFDM	868MHz, 915MHz, 2.4 GHz (unlicensed); Direct Sequence Spread Spectrum coding.
Channel bandwidth	20 MHz or 25 MHz (United States) or 28 MHz (European Country)	Wide band 1200Hz; Medium band 600Hz	20MHz for 802.11 a/g; 20MHz or 40MHz for 802.	Nominal bandwidth of 22MHz.	

Coverage capabilities	3-4 miles; longer distances capable with lower bitrates	Distances of more than 15 Km can be achieved over a medium voltage network	Indoor: up to 100 m; Outdoor: up to 250 m	Up to 50 m
Peak single user data rate	Typical 4Mb/s to 16Mb/s	Low-frequency (100-200 KHz) carriers: Few hundred bits per second; Higher data rates mean shorter ranges. Speeds up to 10 Mb/s have been achieved.	802.11b: up to 11Mb/s; 802.11 a/g/h/j: up to 54Mb/s; 802.11n: >100Mb/s	20Kb/s to 250Kb/s, depending on frequency band.
Cost	Moderate	High cost of implementation and lack of vendors.	Low - widely used and deployed in the consumer market.	Low - intended as a low cost, low power product for low bandwidth applications.
Technology maturity	Mature; 500+ deployments worldwide.	More popular in Europe than North America.	Wi-Fi is a mature, proven interoperable technology.	Fairly new; specifications ratified in 2004, ongoing specifications still in process.
Range	50 Km	15 Km	92 m	70 m to 100 m
Data Rate	70Mb/s	576Kb/s	2.4Gb/s	250Kb/s

## V. PROPOSED DESIGN

The In Home Monitoring Display (IHMD) along with faults measurement like over-voltage, under-voltage, short-circuit and measurement of power factor, frequency etc. as well as protection system attachment with the existing smart metering system. As per the standard values of the voltage and frequency considering the tolerance value, maximum and minimum allowable limits of the above mentioned quantities are already pre-programmed in the microcontroller. The measured quantities like voltage, current, frequency are constantly comparing with the standard values in the microcontroller. Whenever the faults occur by any means i.e., the deviation from the standard values beyond the tolerance level, the pre-defined action by the microcontroller will actuate the solid state relay (SSR) [33] which has the very fast switching capacity to quickly trip the power flow to the load from the source. This facility is the extra level of protection for the consumer along with the meter itself besides the different protection system available at the consumer end. In an extreme case, if incoming power frequency mismatch the standard value beyond the tolerance then the grid will collapse instantly, a huge amount of loss will be incorporated in that situation. The ASBEM will be able to protect and notify the consumer about the fault occurred in the system with the help of SSR, IHMD, Web and Android application linked with the device. As per the real time demand of power, flexi metering system can be adopted by communicating through PLC as well as Zigbee based model by accessing the node and coordinator from the remote end. Dynamic pricing is also an energetic and attractive way of approach with the

optimization of cost of the power generation from the sources as per real time electrical power requirement. The ASBEM shows the power factor, nature of the load i.e., inductive or capacitive in the LCD, LED or OLED based touch screen display.

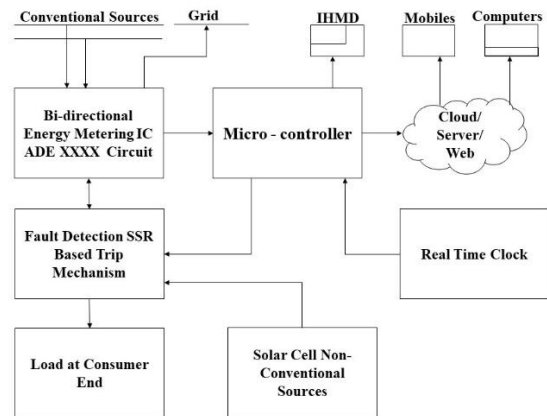

Fig. 5: Block Diagram of The Proposed Model

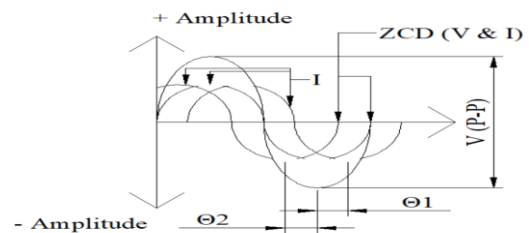

Fig. 6: Measurement Points of The Electrical Power

Type	Conventional Meter	Current Design	Proposed Design
Communication Type	None (Physically Readings Are Taken)	GSM	Wi-Fi / Zigbee / PLC
Payment Method	Post-paid	Prepaid	Prepaid

Data Display	Units	Units, Bill data, Recharge, Power Data	Units, Bill Data, Recharge, Power Data Low Balance/Power Cut Warnings, Fault Detection
User Interface	Gear Based Display	LCD	LCD / LED, IHMD, Web And Android App
Energy Control Methods	No Control	No Control	Relay Control
Back end Interface	No Interface	No Interface	Website and graph plots
Sensing Technology	Magnetic Coupling	CT and PT Integrated to Current Sensors.	IC, CT & PT If Required
Cost In INR	1K	Around 5K-7K	Around 2.5K
Data Collection	Manual	SMS	Cloud, Web Chart and SMS
Fault Prevention	No	No	Yes (Voltage, Current, Frequency)
Measurement	Single	Bi Directional	Uni Directional, Bi Directional

## VI. CONCLUSION

This paper has been basically shown the comparison of advancement of smart meter in different aspect i.e., cost, constructional and communication method. In addition with the existing model to protect from the faults the proposed model can be implemented easily and greater reliability in a cost effective way.

## References:

- [1] Aditya Tiwary, Manish Mahato, Mohit Tripathi, Mayank Shrivastava, Mayank Kumar Chandrol, Abhitesh Chidar, "A Comprehensive Review of Smart Energy Meters: An Innovative Approach", IJFRCSCE, ISSN: 2454-4248239 – 243 Volume: 4 Issue: 4
- [2] Patel Umang, Modi Mitul, "A Review on Smart Meter System", IJREEICE, ISSN (Online) 2321 – 2004 ISSN (Print) 2321 – 5526
- [3] Shaista Hassan Mir, Sahreen Ashruf, Sameena, Yasmeen Bhat and Nadeem Beigh, "Review on Smart Electric Metering System Based on GSM/IOT", Asian Journal of Electrical Sciences, ISSN: 2249-6297, Vol. 8, No. 1, 2019, pp. 1-6
- [4] AMI and Customer Systems: Results from the SGIG Program, [https://www.energy.gov/sites/prod/files/2016/12/f34/AMI%20Summary%20Report\\_09-26-16.pdf](https://www.energy.gov/sites/prod/files/2016/12/f34/AMI%20Summary%20Report_09-26-16.pdf)
- [5] Noelia Uribe-Pérez, Luis Hernández, David de la Vega, Itziar Angulo, "State of the Art and Trends Review of Smart Metering Electricity Grids", Appl. Sci. 2016, 6, 68; doi:10.3390/app6030068 [www.mdpi.com/journal/applsci](http://www.mdpi.com/journal/applsci)
- [6] P. Rakesh Malhotra, Dr. R. Seethalakshmi, "Automatic Meter Reading and Theft Control System by Using GSM", International Journal of Engineering and Technology (IJET), ISSN : 0975-4024 Vol 5 No 2 Apr-May 2013
- [7] Naeem Javed, Muhammad Aamir Shafi, Nasrullah Khan, Mohsin Khan, "Design of a Smart Energy Meter with Overload Trip Facilities", International Journal of Engineering and Advanced Technology (IJEAT), ISSN: 2249 – 8958, Volume-6 Issue-6, August 2017
- [8] Kavita Narayan Mule, Prof. B.T. Deshmukh, "Design of Smart Energy Meter for Smart Grid with Net Metering & Theft Detection", International Journal for Research in Engineering Application & Management (IJREAM), ISSN : 2454-9150 Vol-03, Issue-12, Mar 2018
- [9] Nazmat Toyin SURAJUDEEN-BAKINDE, Sunday Olufenka AYODELE, Timilehin David OLORUNTOBA, Abdulrahman Okino OTUOZE, Nasir FARUK, "Development of an Internet Based Prepaid Energy Meter", IEEE Africon 2017 Proceedings, 978-1-5386-2775-4/17/\$31.00 ©2017 IEEE
- [10] Emerging Smart Meters in Electrical Distribution Systems: Opportunities and Challenges, DOI: 10.1109/IranianCEE.2016.7585682
- [11] IoT based smart energy meter, [www.IJARIT.com](http://www.IJARIT.com), ISSN: 2454-132X
- [12] Issues and Challenges of Existing Electricity Pre-Paid Smart Metering Systems: A Review, Science, Technology and Development 36 (1): 44-52, 2017, ISSN 0254-6418 / DOI: 10.3923/std.2017.44.52© 2017 Pakistan Council for Science and Technology
- [13] Literature Review on Smart Energy Meter, International Journal of Innovative Research in Science, Engineering and Technology, ISSN(Online): 2319-8753ISSN (Print) : 2347-6710
- [14] Microcontroller based Bidirectional Energy Metering for Domestic User, Journal of Electronic Design Engineering Volume 3 Issue 1
- [15] Research Advancements Towards in Existing Smart Metering over Smart Grid, (IJACSA) International Journal of Advanced Computer Science and Applications, Vol. 8, No. 5, 2017
- [16] Review of Smart Meter Data Analytics: Applications, Methodologies, and Challenges, DOI 10.1109/TSG.2018.2818167, IEEE Transactions on Smart Grid
- [17] Smart Metering for Smart Electricity Consumption, School of Computing, Blekinge Institute of Technology, 37179 Karlskrona, Sweden, Master Thesis Electrical Engineering May 2013
- [17] Poly Phase Multifunction Energy Metering IC with Per Phase Information, <https://www.analog.com/media/en/technical-documentation/data-sheets/ADE7758.pdf>
- [18] Single-Phase, Bi-Directional Power/Energy IC, <https://www.cirrus.com/products/cs5460a/>, [https://statics.cirrus.com/pubs/proDatasheet/CS5463\\_F3.pdf](https://statics.cirrus.com/pubs/proDatasheet/CS5463_F3.pdf)
- [19] SINGLE PHASE BIDIRECTIONAL POWER/ENERGY METERING IC WITH INSTANTANEOUS PULSE OUTPUT, <https://www.digchip.com/datasheets/parts/datasheet/454/SA9602HPA-pdf.php>
- [20] CS5460 : Single Phase Bi-Directional Power/Energy IC, Cirrus Logic, <https://pdf1.alldatasheet.com/datasheet-pdf/view/230848/CIRRUS/CS5460.html>
- [21] [http://www.indiasmartgrid.org/reports/AMI%20Roll-Out%20Strategy%20and%20Cost-Benefit%20Analysis%20for%20India\\_ISGW2017.pdf](http://www.indiasmartgrid.org/reports/AMI%20Roll-Out%20Strategy%20and%20Cost-Benefit%20Analysis%20for%20India_ISGW2017.pdf)
- [22] <https://www.thehindubusinessline.com/economy/over-5-lakh-smart-meters-operational-across-india-says-eesl/article29060479.ece>
- [23] Arne Ellerbrock , Ahmad Abdel-Majeed, and Stefan Tenbohlen on "Design and Building of a Cheap Smart Meter" in proceeding with Institute of Power Transmission and High Voltage Technology, Pfaffenwaldring 47, 70569 Stuttgart, Universität Stuttgart, Germany
- [24] <https://www.analog.com/media/en/technical-documentation/application-notes/AN-679.pdf>
- [25] <https://www.scribd.com/doc/223321317/MINOR-REPORT-ON-Energy-Meter-using-ADE7757>
- [26] G. Eason, B. Noble, and I. N. Sneddon, "On certain integrals of Lipschitz-Hankel type involving products of Bessel functions," Phil. Trans. Roy. Soc. London, vol. A247, pp. 529–551, April 1955. (references)
- [27] J. Clerk Maxwell, A Treatise on Electricity and Magnetism, 3rd ed., vol. 2. Oxford: Clarendon, 1892, pp.68–73.
- [28] I. S. Jacobs and C. P. Bean, "Fine particles, thin films and exchange anisotropy," in Magnetism, vol. III, G. T. Rado and H. Suhl, Eds. New York: Academic, 1963, pp. 271–350.
- [29] R. Nicole, "Title of paper with only first word capitalized," J. Name Stand. Abbrev., in press.
- [30] Y. Yorozu, M. Hirano, K. Oka, and Y. Tagawa, "Electron spectroscopy studies on magneto-optical media and plastic substrate interface," IEEE Transl. J. Magn. Japan, vol. 2, pp. 740–741, August 1987 [Digests 9th Annual Conf. Magnetism Japan, p. 301, 1982].
- [31] M. Young, The Technical Writer's Handbook. Mill Valley, CA: University Science, 1989.
- [32] <https://www.huimultd.com/INFORMATION/Solid-State-Relays-Intro/>